

Futura HD 150 Brattpan

Model – Futura HD (3756283)

STANDARD FEATURES

- Stainless steel frying surface
- Elevated control pillar
- Aluminum encased flat heating elements
- Temperature control to 250°C
- 2-zone heating
- Water filling to pan.
- Electric tilting motor.
- Depth 273mm
- 3 GN format
- Construction of AISI 304 and 403 stainless steel
- Insulated and balanced lid
- Rounded corners of inner pan
- Recoiled hand-shower
- Emergency all stop control button.



Net Volume 150L
Geo Volume 170L

Connections
Water Cold ø3/4"

Waste By kitchen contractor
Net Weight 320 kg
Frying surface – 0.59m²
Power of Single Heating element 2.3 kW

Dimensions
Width 1553 mm
Height 1559mm
Depth 955mm

Electrical
Power 27.6 kW
Voltage 400V,
3P+N+E 50/60Hz
AMP 50A

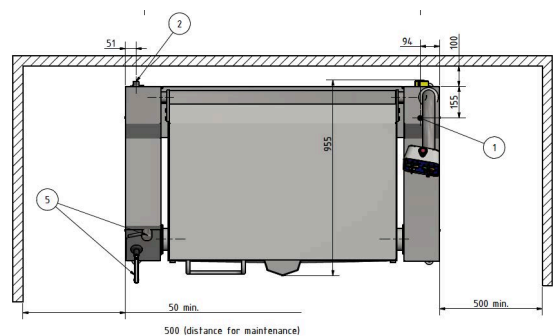
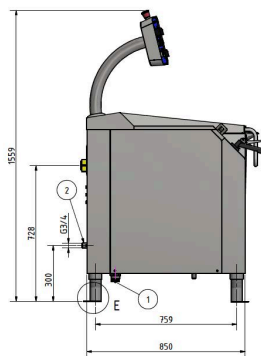
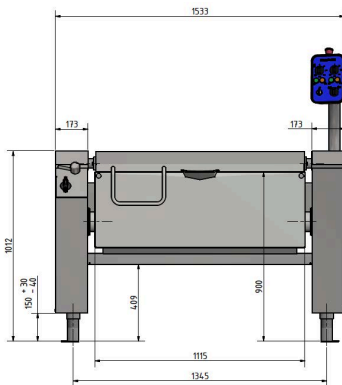

Finland
metos.com/manufacturing

Metos Oy Ab
Ahjonkaarre
FI 04220 Kerava
Finland
Telephone +358 204 3913
international.sales@metos.com

1. Cable gland PG36 for electrical supply cable. Reserve 1,0m of power cable above floor level.
2. Cold water connection G3/4, one-way valve must be fitted. Valve not included in delivery.
3. All four feet should be fixed to the floor. Mounting screws not included in delivery.
4. Requirements, given in Installation manual must be followed.

Disclaimer: All unit capacities are based on subjective testing.

In line with policy to continually develop and improve its products, Metos Oy Ab reserves the right to change specifications and design without notice.