

PROJECT	QUANTITY	ITEM NO
---------	----------	---------

Rotisserie



SCR 8 8-spit
Countertop

SCR 16 16-spit
Stacked



SCR 8 countertop
8-spit rotisserie



SCR 16 stacked
16-spit rotisserie

The sight, smell and taste of rotisserie chicken can add significant impact and sales to your store. With such a powerful appeal to the senses, choosing your equipment is critical.

But why choose Henny Penny rotisseries? You'll get *more* of those delicious whole birds, ribs, pork roasts and other center-of-the plate items every day because the Henny Penny rotisserie simply cooks faster.

THERMA-VEC® Even Heat Process combines cross-flow convection cooking with radiant heat. The result is thorough, even cooking with uniform browning in a lot less time than other rotisseries.

The single cabinet SCR 8 countertop rotisserie saves on floor space while cooking up to 40 whole birds in a single load! The stacked SCR 16 doubles that production—a massive 80 whole birds per load—from the same footprint, while providing the flexibility of two independently operated rotisseries.

With 9 available cook cycles (per cabinet) and choice of browning level, chefs can dial up just the right color and crispness for seasoned and marinated meats, fish and poultry... every time!

Easy-to-use controls feature LED displays and probe cooking. Units can be configured with various features on control side and customer side.

Spits, rotor disks, drive tube and drip trays remove easily for cleaning and are made with coated surfaces for easy cleanup.

Henny Penny offers a host of accessories including mobile loading stands, product display units, and merchandising bases that increase productivity and impulse sales.

Standard Features

- THERMA-VEC® Even Heat Process cooks full loads quickly and evenly:
 - Gentle, cross-flow convection for even cooking throughout cabinet
 - Radiant heat for uniform browning and crisp texture
- Easy-to-use touch key controls with large LED simultaneous time and temperature display
- 9 programmable cook cycles for each cabinet, 18 total for SCR 16
- Programmable browning and texture control
- Food temperature probe
- Tempered clear glass doors with black matrix shaded borders
- Rotation stops automatically when doors open
- Spit rotation switch for easy loading
- Interchangeable spits, racks or baskets
- Simple three-piece drive tube and rotor assembly
- Drive assembly, drip trays and drain pans disassemble easily for quick cleanup
- Coated spits and interiors for easy cleaning
- Stainless steel construction for easy cleaning and long life

Please choose configuration

- 8 or 16 angled spits OR
- 8 or 16 piercing spits OR
- 8 or 16 solid bottom baskets OR
- 8 or 16 wire baskets
- Cabinet style
 - Solid back
 - Pass-through
 - Customer side door handle
 - with without
 - Customer side rotation switch
 - with without
 - 4 casters 3 in (76 mm)
 - SCR 16 low profile caster mounting
 - Adjustable leveling legs
 - SCR 8 no casters or leveling legs

NOTE: Each cabinet in a stacked unit must be configured identically. Stacking Kit 02665 shipped with order.

<input type="checkbox"/> APPROVED	<input type="checkbox"/> APPROVED AS NOTED	<input type="checkbox"/> RESUBMIT
AUTHORIZED SIGNATURE		DATE



Rotisserie

SCR 8 8-spit
Countertop

SCR 16 16-spit
Stacked

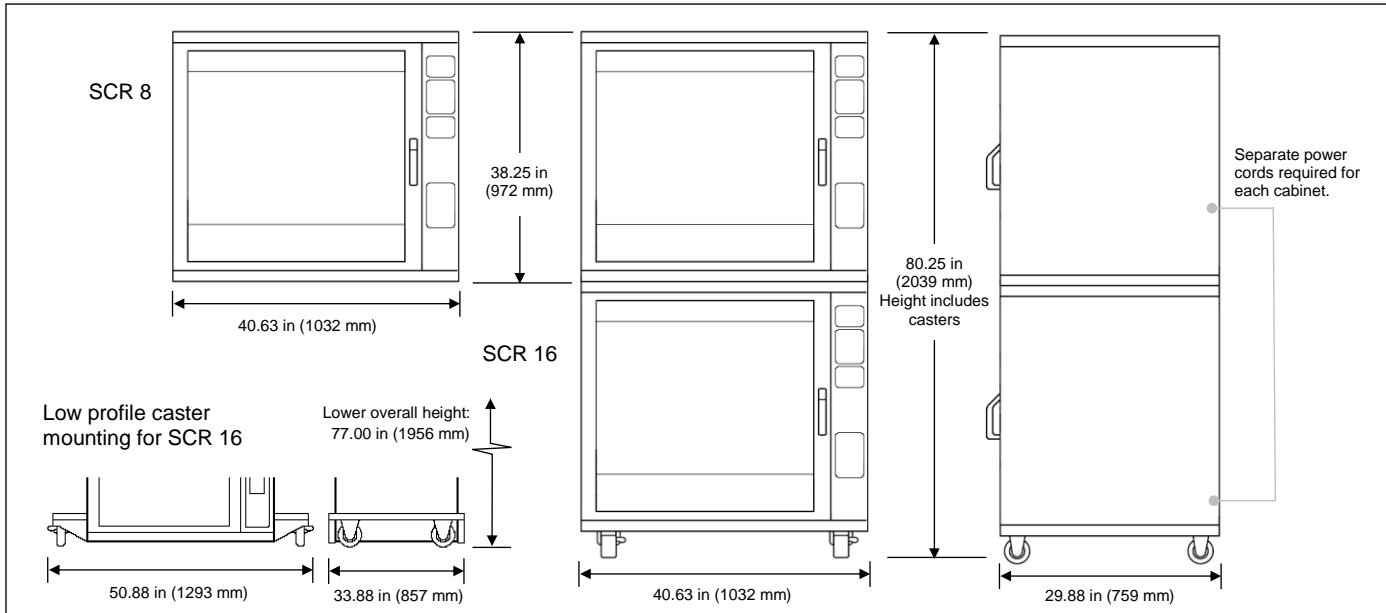

SCR 8

SCR 16 Stacked

Dimensions

	SCR 8	SCR 16 Stacked
Height	38.25 in (972 mm)	80.25 in (2039 mm)
Width	40.63 in (1032 mm)	40.63 in (1032 mm)
Depth	29.88 in (759 mm)	29.88 in (759 mm)

Crated

	SCR 8	SCR 16 Stacked
Length	48 in (1220 mm)	
Depth	37 in (940 mm)	2 crates SCR 8
Height	48 in (1220 mm)	
Volume	49.3 ft ³ (1.40 m ³)	98.6 ft ³ (2.80 m ³)
Weight	471 lb (214 kg)	942 lb (428 kg)

Capacity 2.5 lb (1.1 kg) whole chickens

	SCR 8	SCR 16 Stacked
8 spits		16 spits
Angled spits	32 chickens 4 per spit	64 chickens 4 per spit
Piercing spits	40 chickens 5 per spit	80 chickens 5 per spit
Basket	32 chickens 4 per spit	64 chickens 4 per spit

Heating Electric convection and radiant heat

Lighting 4 tungsten halogen lamps 150 W

Electrical

Volts	Phase	Hertz	kW	Amps	Wire*	Cord & Plug
208	1	50/60	11.1	53.4	2+G	US and Canada 3 phase 208 V and 240 V only
240	1	50/60	11.1	46.3	2+G	
208	3	50/60	11.1	33.6	3+G	NEMA 15-50P
240	3	50/60	11.1	29.1	3+G	
400	3	50	11.1	19.3	3NG	

Not available for all destinations

US and Canada 3 phase 208 V and 240 V only

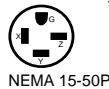

Required clearances

Left	2 in (50 mm) air flow
Right	20 in (500 mm) service, power cord
Back	2 in (50 mm) air flow
	3 in (76 mm) when stacked
	28 in (711 mm) pass-through door open
Front	28 in (711 mm) door open

Bidding Specifications

Provide Henny Penny electric rotisserie model SCR 8 countertop with 8 spit capacity or SCR 16 stacked with 16 spit capacity. When stacked to form SCR 16 both SCR 8 cabinets must be configured alike.

Unit shall incorporate:

- THERMA-VEC® Even Heat Process combines cross-flow convection heat with radiant heat
- Programmable cooking programs with programmable browning and texture settings
- Large LED displays for time and temperature
- Food probe and probe cooking capability
- Pass-through or solid back design
- Removable coated spits, rotor disks, drive tube, drip tray
- High-quality stainless steel and tempered glass
- Choice of handle and rotation switch for customer side and service side
- Choice of 8 angled or piercing spits, or baskets for each cabinet
- Choice of casters or leveling legs for single or bottom unit, or low profile casters for SCR 16

Laboratory certifications



*Units shipped without power cord and plug must have power cord and plug installed on site by a qualified electrician.

Continuing product improvement may subject specifications to change without notice.

24 Hour Technical Support:

Henny Penny Technical Service
800 417.8405
technicalservices@hennypenny.com

Henny Penny Corporation
PO Box 60 Eaton OH 45320 USA

+1 937 456.8400 800 417.8417
+1 937 456.8434 Fax 800 417.8434 Fax
www.hennypenny.com

HENNY PENNY
Engineered to Last